

SETSOLAR assembles its own photovoltaic modules using guaranteed and certified materials.

This module meets industry standards for consumer safety and reliability and is covered by a comprehensive 20 year warranty.

Low-iron tempered glass is designed to resist impact and increase light transmittance, thus improving daily power generation.

Encapsulating the solar cells between Tempered Glass / EVA / Tedlar guarantees a durable protection for the cells during extreme weather conditions.

The strong aluminium frame with pre-drilled mounting holes allow for easy installation.

Each solar module is equipped with a pre-wired IP65 junction box, which includes MC equivalent connectors and protective bypass diodes.

Furthermore is each solar module submitted to an individual quality inspection, certifying product quality and output power performance.

Modules designed and manufactured according to IEC 61215 & IEC 61730 standards.

APPLICATIONS

- Signalling ●
- Streetlights ●
- Water pumping ●
- Rural Electrification ●
- Telecommunication ●
- Billboard illumination ●

CONTACT US

Unit 8, 98b Bofors Circle, Epping Ind. 2
Cape Town, South Africa, 7460
Tel: 021 535 1978 or 021 535 1741
Admin Fax: 021 534 0233
Sales Fax: 021 534 5730
Int: +27 21 535 1794
info@setsolar.co.za
www.setsolar.co.za

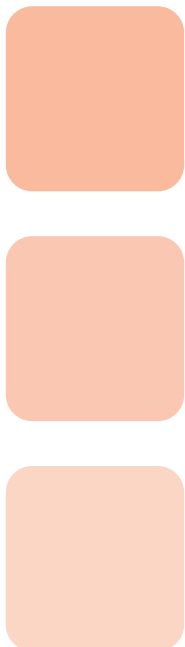

*Image for illustration purposes only

SETSOLAR M850P

TYPICAL PERFORMANCE CHARACTERISTICS

Typical power (Wp)	65	70	75	80	85	90
Tolerance (%)	+/- 5%					
Voltage at max.power (V)	17.0	17.3	17.6	17.9	18.2	18.4
Current at max.power (A)	3.90	4.10	4.30	4.50	4.70	4.90
Open circuit voltage (Voc)	21.4	21.6	21.8	22.0	22.2	22.4
Short circuit current (Isc)	4.50	4.70	4.90	5.10	5.30	5.50

Standard test conditions: 1000W/m², AM1.5G and 25 degree C

TEMPERATURE COEFFICIENTS

Voltage	-79.20mV / degree C
Current	+1.55mA / degree C
Power	-0.46% / degree C
NOCT (degrees)	45

CELLS

Type	Monocrystalline
Dimensions	125mm x 125mm
Layout	36 cells (4rows x 9cells)

GENERAL INFORMATION

Maximum System voltage	715V
Diodes	2 x 10A bypass
Type of connection	Pre-wired IP65 junction box with MC equivalent connectors
Frame	25mm black anodized aluminium
Weight (kg)	7.7
Packaging	4 modules per carton box

WARRANTY

Product	5 years
Power output	Terrestrial: 20 years / 80% yield Marine: 10 years / 90% yield

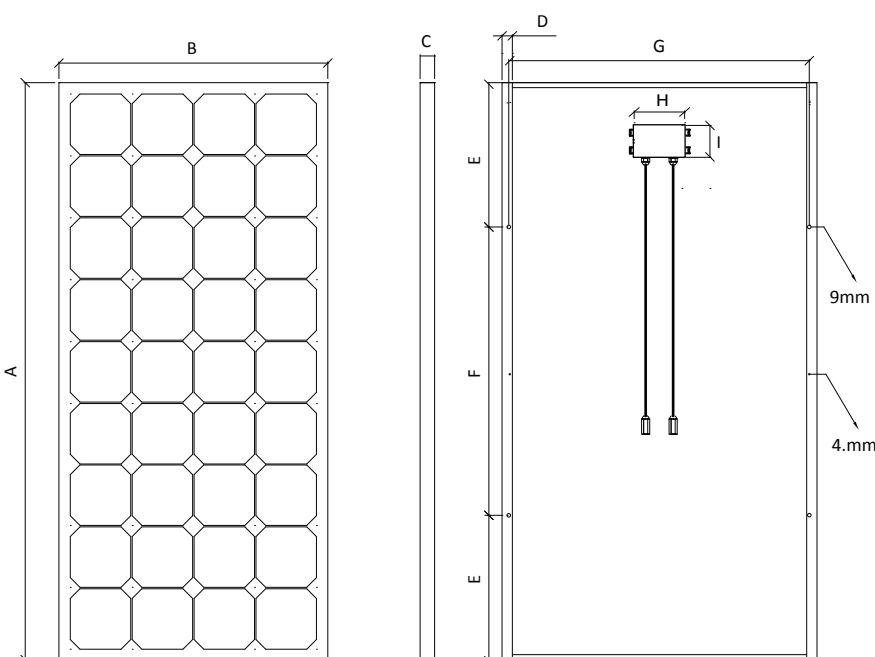
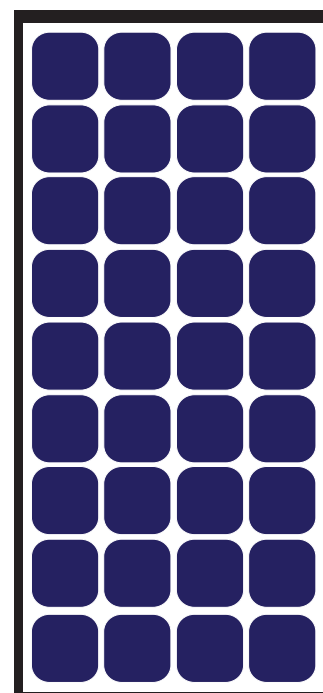

DIMENSIONS

A	1196
B	542
C	25
D	25
E	348
F	500
G	508
H	118
I	70

Dimensions in mm
(tolerance +/-4mm)

** SETSOLAR reserves the right to modify all data without notice, due to continuous product development.